

Confirmation of workpiece on moving pallet

moving

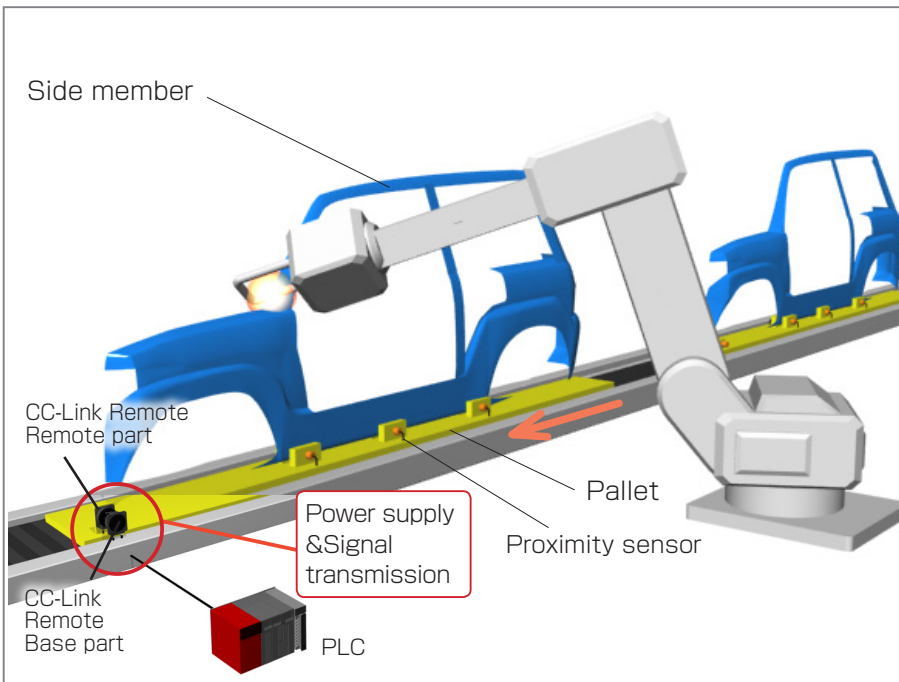

Problems

- Connection failure caused by spatter and other contaminants caused unnecessary stop of the production line.
- Maintenance required for contact pins.

Solution



Remote system

Advantages

- Eliminated unnecessary stop of the production from spatter and other contaminants.
- Eliminated maintenance of the contact pins with the non-contact system. Sputter resistant surface eliminated sputter accumulation.

Application

Weld Sidemember placed on pallet.

8 proximity switches are used to confirm seating of the Sidemember on the pallet. Spatter resistant surface makes the cleaning easy, even in event of spatter contamination.

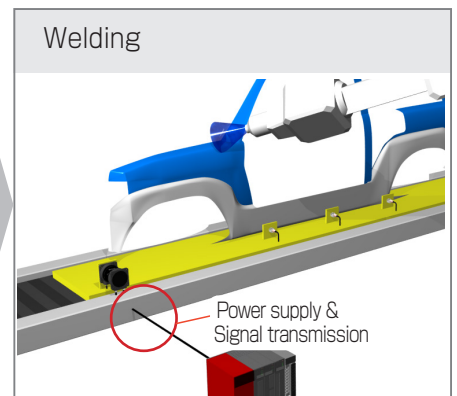
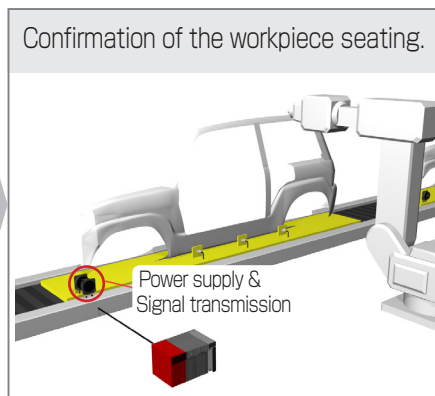
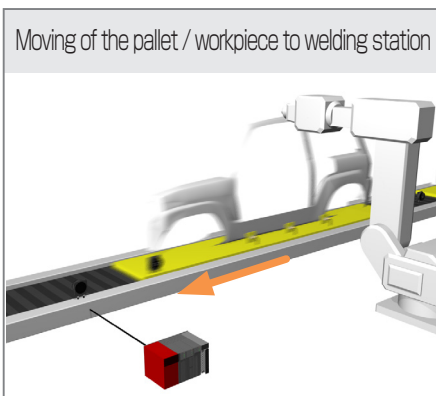

Construction of devices

