

Simple RFID  
8/10-Bit Read System

ID reader unit  
Z5-CA01N-PU\_\_ / Z5-CA01P-PU\_\_  
Z5-DA01N-PU\_\_ / Z5-DA01P-PU\_\_

Manual



■ Index ■

1. Description

1.1 Description . . . . . 3

1.2 System configuration . . . . . 3

1.3 Tag format for 8/10-bit read system . . . . . 3

2. Specifications . . . . . 4

3. Installation and Wiring . . . . . 6

4. Communication with the External Unit . . . . . 7

5. Input Signal (Device) Error Detection . . . . . 7

6. Input Signal (Device) Appropriate Data carrier and Read distance of 8 bit Reader . . . . . 8

**Safety Considerations**

(Read this section thoroughly before installation.)

Before using this processor, read this manual carefully and operate properly, paying attention to the safety aspects.

Notes for designing :

- ◆ Reader together with data carrier which are specified by ISO15693 standard comprise the identification system and may only be used for this purpose in industrial applications.
- ◆ Please design the system to work safely in case of the unit malfunction or external power supply failure.
- ◆ Power supply / condition of use, design the system not to exceed the specifications of the unit as indicated in the user's guide or manuals.

Precautions :

- ◆ Use a regulated power supply, e.g. switch-model type.  
Do not exceed the specified rated voltage as it may cause overheating or ignition.
- ◆ When wiring the processor, follow the chapters containing the wiring diagrams closely, and wire all connections properly. Mis-wiring or wrong connection may cause unexpected malfunction and breakdown of the unit.
- ◆ Please turn off the Remote System before any performances such as mounting, maintenance or breakdown.
- ◆ Do not disassemble or modify the processor.  
Which may cause failure, malfunction, injury or fire.
- ◆ To avoid malfunction caused by induction noise, cable should be kept apart from motor or other power cable.
- ◆ When disposing the product, please treat it as industrial waste.



## 2. Equipment specification

### General specification

Type code	Z5-CA01N-PU__	Z5-CA01P-PU__	Z5-DA01N-PU__	Z5-DA01P-PU__
Number of bits	8-bit		10-bit	
Output specification	NPN	PNP	NPN	PNP
Power supply	24V DC ± 10%			
Current consumption	max.200mA (includes read/write head)			
Use ambient temperature	0...+50°C			
Operating humidity	35...90%RH			
Protective class	IP 67			
Vibration rating	10...55Hz, amplitude 1.5mm, to each axis X-Y-Z for 2 hrs.			
Shock rating	50G, 3 times to each axis X-Y-Z, total 18 times			
Housing material	ABS			
Cable	R/W head side	PU sheath φ 7 (8x24AWG)		PU sheath φ 7 (8x24AWG)
	PLC side	PU sheath φ 7.7 (2x21AWG+9x25AWG)		PU sheath φ 8.6 (2x21AWG+16*x25AWG)
Weight	350G (cable length 2m)		400G (cable length 2m)	

Actually used lines are 11 out of 16 (see page 6).

### Correspondence RFID chip

Supports the communication protocol of the ID chip shown on the right chart.

Please confirm the processing time, communication distance and quality when using anything other than Data carrier (the Z1 series)

chip	Manufacturer	Capacity
MB89R118	Fujitsu	2000byte(FRAM)
I-CODE SLI, SLIX	NXP	112byte
Tag-it HF-I plus	TI	256byte
my-d(SRF55V02P)	Infineon	224byte
my-d(SRF55V10P)	Infineon	992byte
Tag-it HF-I standard	TI	32byte
Tag-it HF-I pro	TI	32byte

I - CODE SLI, SLIX is NXP semiconductor, FRAM is Ramtron International, Tag - it is Texas Instruments Incorporated, my - d is a registered trademark of Infineon Technologies AG.

### Dimension

#### • 8-bit Specification

Z5-CA01N-PU\_\_

Z5-CA01P-PU\_\_

#### • 10-bit Specification

Z5-DA01N-PU\_\_

Z5-DA01P-PU\_\_

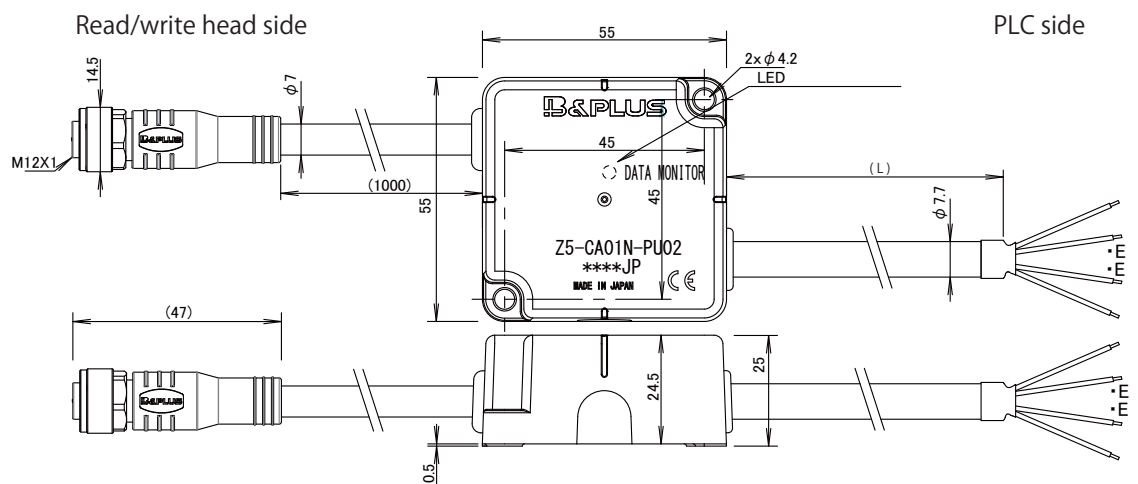

L = Cable length

Standard : 2m (Max 10m)

ID reader unit

■ LED status

Color	LED status	Description of the functions		
Yellow	ON	---	Data carrier present and data are valid It is in normal condition.	
	OFF	---	The Data carrier is not in the communication range.	
	Blink	1 s interval		An error has occurred in the data check.
		100 ms		Any of those "ON" output signals that indicate Read data or Data valid is short circuit.
		4 s interval		The ID antenna is not connected. Please connect the ID antenna or check the wiring.
2 s interval			Communication between read/write head and ID reader unit is abnormal.	

The blinking interval is the interval of lighting / extinguishing time.

For 1s interval, repeat 0.5 seconds lighting / 0.5 seconds off.

■ Output specification

Load voltage	30 V DC (max.)
Load current	50mA (max.)
Residual voltage	≤ 1.5V
Load current	≤ 0.08mA

■ Output circuit

NPN type      Z5-CA01N-PU\_\_  
                   Z5-DA01N-PU\_\_

PNP type        Z5-CA01P-PU\_\_  
                   Z5-DA01P-PU\_\_

ID reader unit

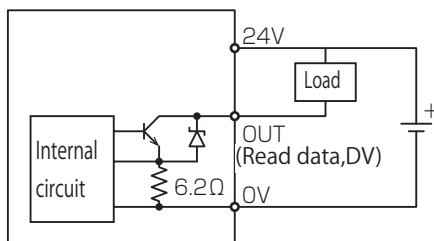

ID reader unit

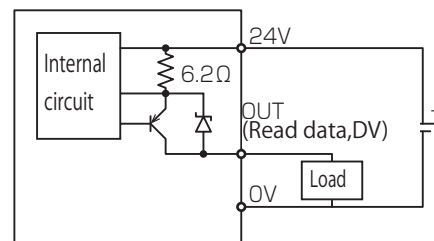

■ Output signal

Signal	I/O	Cable color	Contents
Power supply 24V	-	White	Connect (+) side of the 24V DC Power supply
Power supply 0V	-	Pale Blue	Connect (-) side of the DC24V Power supply
Reading Data D0	Out	Brown	Output data read from Bit address [ 0 ]
Read data D1	Out	Red	Output data read from Bit address [ 1 ]
Read data D2	Out	Orange	Output data read from Bit address [ 2 ]
Read data D3	Out	Yellow	Output data read from Bit address [ 3 ]
Read data D4	Out	Green	Output data read from Bit address [ 4 ]
Read data D5	Out	Blue	Output data read from Bit address [ 5 ]
Read data D6	Out	Violet	Output data read from Bit address [ 6 ]
Read data D7	Out	Gray	Output data read from Bit address [ 7 ]
Read data D8	Out	brown/black •	Output data read from Bit address [ 8 ]
Read data D9	Out	red/black •	Output data read from Bit address [ 9 ]
Data valid DV	Out	Black	Output signal that indicates the read data is valid

The read data D8 and D9 are valid only for the 10-bit specification.

### 3. Installation and Wiring

#### ■ Installation

When attach the ID reader writer, communications distance may shorten. To avoid influence of the metal and interference, please install the greater value mentioned in the diagram below. Also, note that Data carrier can not be metal installed.

#### ■ Metal installation

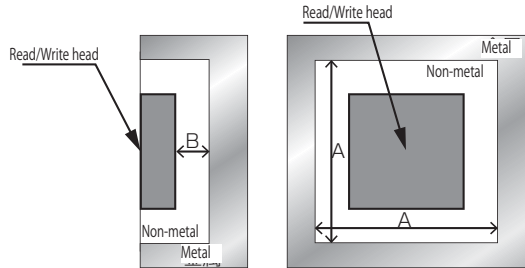

#### ■ Parallel Setting

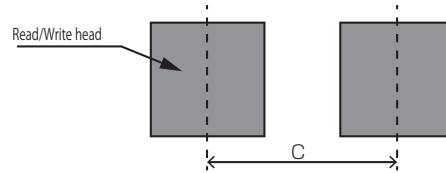

Mounting	Type code	Non-metallic area (mm)		Mutual interference(mm)
		A	B	C
Metal mounting	Z3-A010-CN	200	0	500
Non-metal mounting	Z3-A010-CN	200	40	500

Metal installation means to install directly on top of the metal. Circumference (A) is non-metal region.

• Non-metal installation is to have an area (A) metal and reader write, then also back(B) has the non-metal area.

#### ■ Wiring

[ NPN type ]

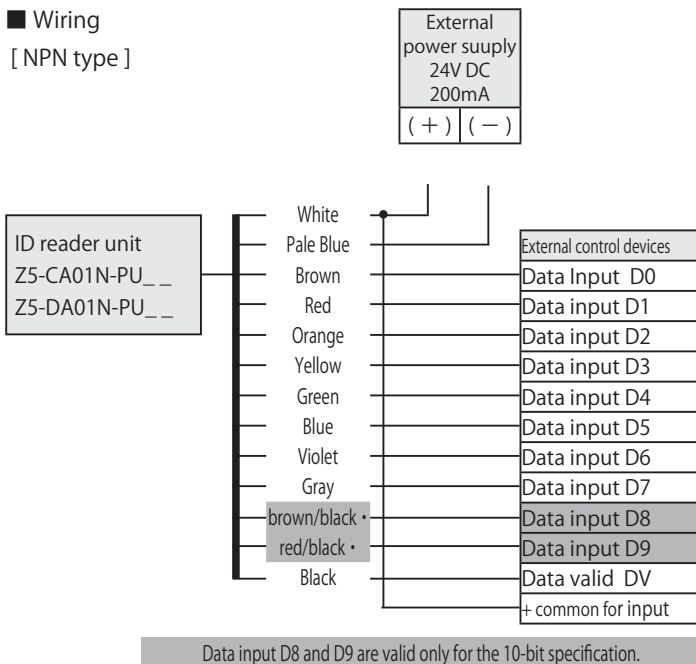

#### ■ Wiring

[ PNP type ]

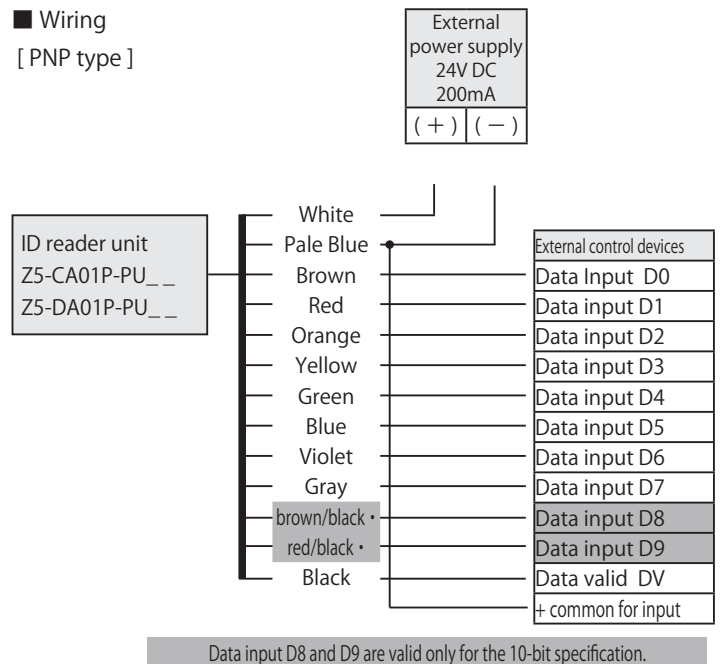

■ Data input D8 and D9 are valid only for the 10-bit specification.

At factory shipment, Z5-DA01N-PU\_\_ and Z5-DA01P-PU\_\_ are cutting unused cables. If you shorten the cable due to wiring reasons etc., unused cables will be exposed, so please handle so as not to short-circuit. The unused cables are "Orange / Black Dot", "Yellow / Black Dot", "Green / Black Dot", "Blue / Black Dot", "Purple / Black Dot".

#### ■ About cable length

● PLC (external control equipment) side ... standard is 2 m. It can extend up to 10 m.

The end of type name "02" means a cable length of 2 m. It is "... PU - 01" when requesting 1 m.

- When connecting user's cable to Reader, be sure to use the cable of which conductors are bigger than 0.5 mm<sup>2</sup> for power supply line (white, pale blue) and 0.2 mm<sup>2</sup> for signal line (brown ... black).

#### 4. Communication with the External Unit

##### ■ Data Reading

[Timing chart 1]

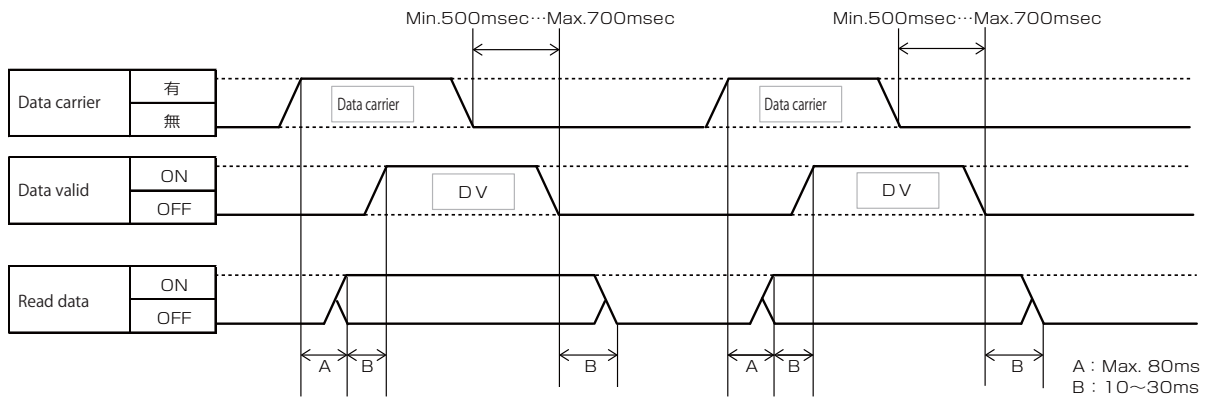

[Timing chart 2]

The reader unit outputs data of tag 2 as shown below when the Data carrier 2 enters the communicable area during the output data preservation period of the Data carrier 1.

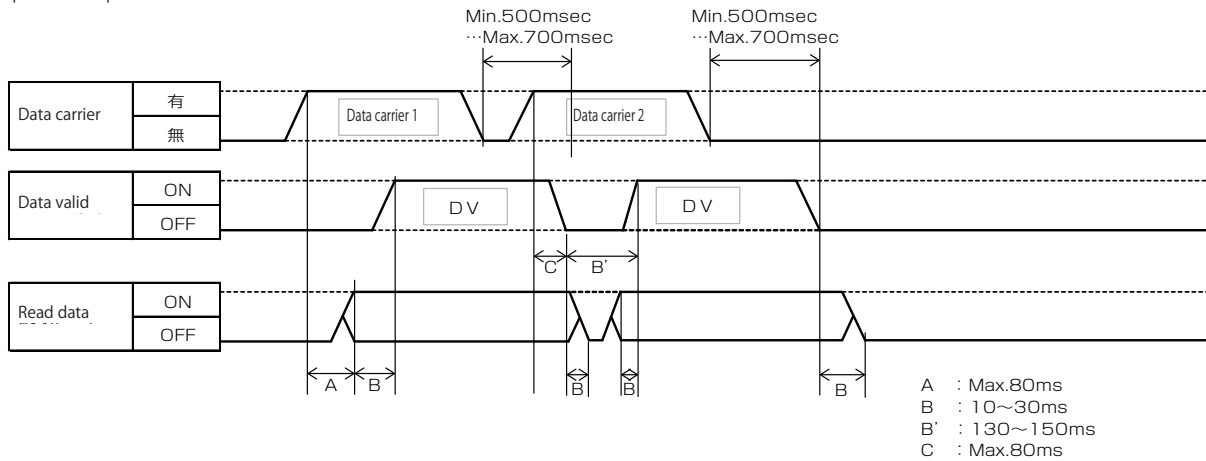

##### [ Procedure for Communication ]

- (1) Reader reads the data of the Datacarrier Reading as soon as the Data carrere comes into the communication area of the reader and set the read data.
- (2) The host computer should start reading from D0 to D7 of Reader after checking the data valid signal turns ON.

##### ◀ Note ▶

If multiple Data carriers exist in the communication area of the ID antenna, data validity will not be turned ON.  
 When a data check error occurs, data valid (DV) remains OFF, and read data is not output.  
 In this condition, LED of data valid would be blinking (slow).

#### 5. Error detection method

LED status		Description of the functions	Output signal
OFF	---	The Data carrier is not in the communication range.	Data valid : OFF
Blink	1 s interval	An error has occurred in the data check.	Data valid : OFF
	100 s interval	Any of those "ON" output signals that indicate Read data or Data valid is short circuit.	---
	4 s interval	The ID antenna is not connected. Please connect the ID antenna or check the wiring.	Data valid : OFF
	2 s interval	Communication between read/write head and ID reader unit is abnormal.	Data valid : OFF

The blinking interval is the interval of lighting / extinguishing time.  
 For 1 s interval, repeat 0.5 seconds lighting / 0.5 seconds off.

6. Input Signal (Device) Appropriate Data carrier and Read distance of bit Reader

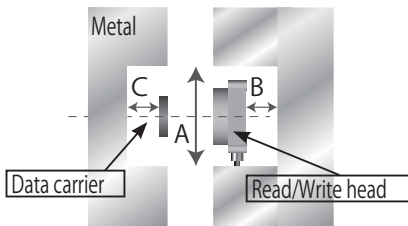

A distance of 200 mm or more is required between the tag and its surrounding A. (See below)

Nonmetallic attachment refers to a state in which the metal and the tag are installed with securing a certain distance (C) or more on the back side.

\*If the surrounding metal specifications are not satisfied, the communication distance may be shortened. Please note that the degree of influence varies depending on the usage environment.

Metal mounting conditions of Z3 - A010 - CN are  $A \geq 200$  mm and  $B = 0$  mm..

· Nonmetallic mounting conditions of Z3 - A010 - CN are  $A \geq 200$  mm and  $B \geq 40$  mm.

· Communication distance, axis offset value are all reference values.

Type code : Z1-CB16-112  
size :  $\varnothing 16 \times 0.76$  mm

Read/write head mounting condition		Non-metal mounting	Metal mounting
ID tag mounting condition		Non-metal mounting (A:200mm, B:60mm)	
Communication distance(mm)		0...44	0...40
Center offset (mm)	distance 0mm	$\pm 26$	$\pm 25$
	10mm	$\pm 28$	$\pm 27$
	20mm	$\pm 30$	$\pm 28$
	30mm	$\pm 30$	$\pm 24$
	40mm	$\pm 25$	$\pm 10$
	44mm	$\pm 10$	—

Type code : Z1-CB27-112  
size :  $\varnothing 27 \times 0.76$  mm

Read/write head mounting condition		Non-metal mounting	Metal mounting
ID tag mounting condition		Non-metal mounting (A:200mm, B:60mm)	
Communication distance(mm)		0...64	0...50
Center offset (mm)	distance 0mm	$\pm 25$	$\pm 25$
	10mm	$\pm 28$	$\pm 27$
	20mm	$\pm 32$	$\pm 29$
	30mm	$\pm 36$	$\pm 29$
	40mm	$\pm 38$	$\pm 23$
	50mm	$\pm 36$	$\pm 10$
	60mm	$\pm 28$	
	64mm	$\pm 10$	

Type code : Z1-CB45-112  
size :  $\varnothing 45 \times 0.76$  mm

Read/write head mounting condition		Non-metal mounting	Metal mounting
ID tag mounting condition		Non-metal mounting (A:200mm, B:60mm)	
Communication distance(mm)		0...88	0...80
Center offset (mm)	distance 0mm	$\pm 32$	$\pm 32$
	10mm	$\pm 32$	$\pm 32$
	20mm	$\pm 37$	$\pm 37$
	30mm	$\pm 42$	$\pm 40$
	40mm	$\pm 47$	$\pm 42$
	50mm	$\pm 48$	$\pm 42$
	60mm	$\pm 47$	$\pm 39$
	70mm	$\pm 42$	$\pm 27$
	80mm	$\pm 30$	$\pm 10$
88mm	$\pm 10$		

Type name : Z1-AA04-02K  
Size : 30 x 30 x 6mm

Mounting conditions of Read/Write head		Non-metal mounting	Metal mounting
Mounting conditions of Data carrier		Non-metal mounting (C:60mm)	Non-metal mounting (C:60mm)
Communication distance (mm)		0 ~ 34	5 ~ 22
Center offset (mm)	Distance 0mm	$\pm 26$	-
	5mm	$\pm 26$	$\pm 20$
	10mm	$\pm 26$	$\pm 20$
	15mm	$\pm 26$	$\pm 15$
	20mm	$\pm 24$	$\pm 5$
	25mm	$\pm 20$	-
	30mm	$\pm 10$	-
	34mm	$\pm 0$	-

Type name : Z1-B011-128  
Size :  $\varnothing 50 \times 8.3$  mm

Mounting conditions of Read/Write head		Non-metal mounting	Metal mounting
Mounting Condition of Data carrier		Non-metal mounting (C:30mm)	Non-metal mounting (C:30mm)
Communication distance (mm)		0 ~ 54	0 ~ 45
Center offset (mm)	Distance 0mm	$\pm 31$	$\pm 23$
	10mm	$\pm 36$	$\pm 25$
	20mm	$\pm 38$	$\pm 27$
	30mm	$\pm 36$	$\pm 25$
	40mm	$\pm 31$	$\pm 17$
	50mm	$\pm 20$	-
	54mm	$\pm 0$	-

Wireless Power Supply by  
**B & PLUS K.K.**

Mail sales@b-plus-kk.jp

Web : <http://www.b-plus-kk.com>

\* Info may change the mention contents such as specifications without a notice.

Thank you for understanding