

Remote Sensor System
Switch signal Terminal unit version
8 signals transmission

Remote terminal : RS8TA-222D-S04, RS8T-222D-S04
RS8TA-222P-S04, RS8T-222P-S04
Transmission head : RSH8T-030-PU-CP-_, RSH8T-TF030-PU-CP-_
Output head : RSH8E-030N-PU-_, RSH8E-TF030N-PU-_
RSH8E-030P-PU-_, RSH8E-TF030P-PU-_

Attention for Installation

(Read this section thoroughly before installation.)

Before using the Remote Sensor, read this manual carefully.
During installation and operation, pay close attention to the safety aspect.

- Ensure the power is switched off during installation or maintenance operations.
- Use a regulated power supply, e.g. switch-model type. Simpler power supplies, such as a full-wave rectification type, will cause the permissible ripple rating to be exceeded and may cause malfunction.
- Ensure correct connections by reference to the wiring diagram.
- To avoid malfunction caused by induction noise, cable should be kept apart from motor or other power cable.

Construction of the system

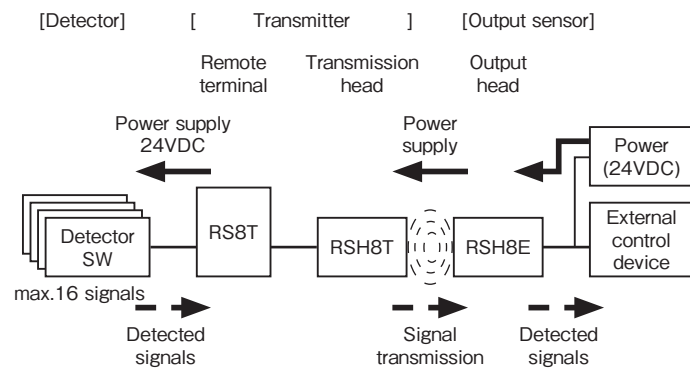

【Function of each component】

- Detector SW : Detected signals is transmitted to Remote terminal.
- Remote terminal : DC2W/Mechanical switch or DC3W switch is connected and detected signals is transmitted to Transmission head.
- Transmission head: Provides power for Detector SW, also passes detected signals from Detector to Output Head.
- Output head : Puts out detected signal to external controller, also sends power for operating of Detector and Transmitter.
- Anti-weld slag type : Fluorine resin cap & Fluorine resin coated housing to protect against weld slag (TF in type name)

Transmission head / Output head specification

Transmission head : RSH8T-030-PU-CP-_, RSH8T-TF030-PU-CP-_
Output head : RSH8E-030 □ -PU-_, RSH8E-TF030 □ -PU-_

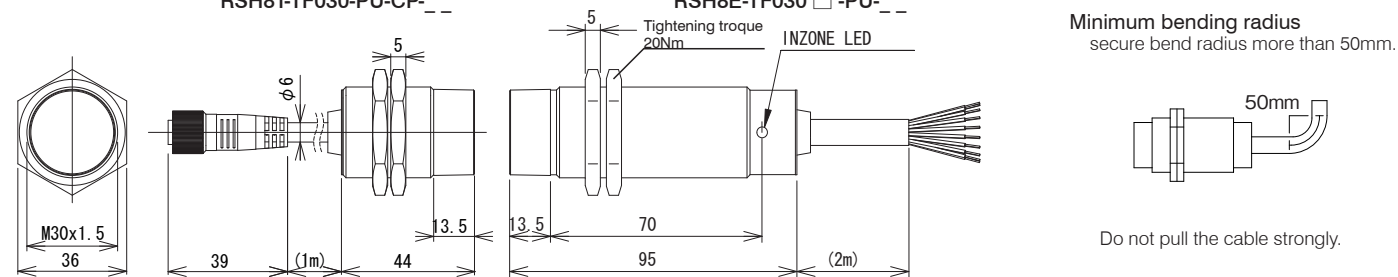

A057	
Transmission head	Standard type
Type code	RSH8T-030-PU-CP-_, RSH8T-TF030-PU-CP-_
Operating distance	2...8 mm
Center offset	±3 mm
Connection cable	M12 connector
Material Housing	Nickel plated brass
Operating surface	Nylon 12
Ambient temperature	0...+50 deg.C.
Protection class	IP 67

(Note)
Please note that the cable length of an output sensor may not longer than 10m.
The CE marking verifies that our products comply with the requirements of EMC directive.
The surge test to an output sensor is not carried out .
When using an output sensor with cable length longer than 10m, a measure to protect the sensor from surge current should be taken.
Please note that the signal may become unstable (false signal or chattering) when the transmission distance and the center offset are outside the specification range.

The inzone signal is a preliminary signal for confirming that the output signal is established within the specification range. Please note that it does not guarantee signals output outside the specification range.

Typical Transmitting Diagram
(Supply voltage at 24V/non-flush mount)
RSH8T-030-PU-CP / RSH8E-030 □ -PU
RSH8T-TF030-PU-CP / RSH8E-TF030 □ -PU

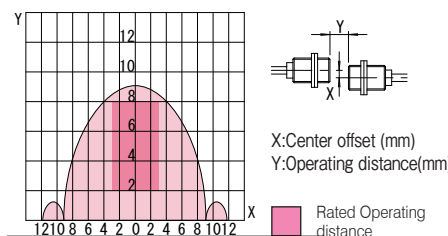

Installation

Influence of surrounding metal and Mutual interference

In order to avoid influence of surrounding metal, or to avoid mutual interference between parallel-mounted sensors, keep the minimum space as described below.

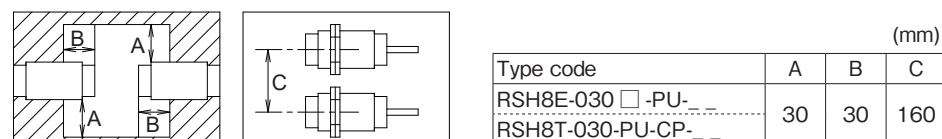

Wiring

■ RSH8E-030N-PU-_, RSH8E-TF030N-PU-_ (NPN)

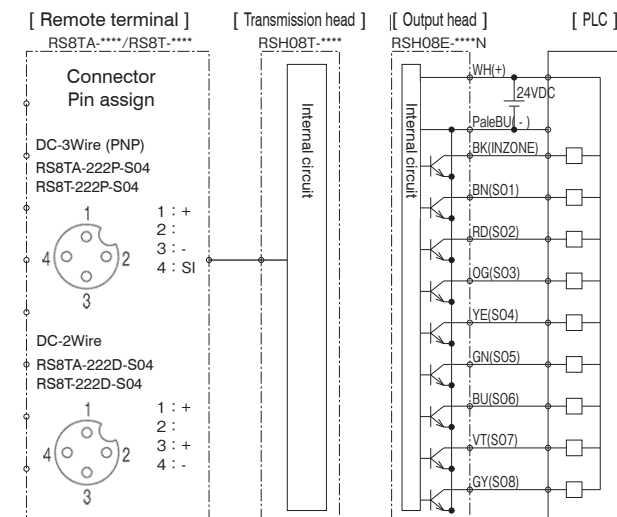

■ RSH8E-030P-PU-_, RSH8E-TF030P-PU-_ (PNP)

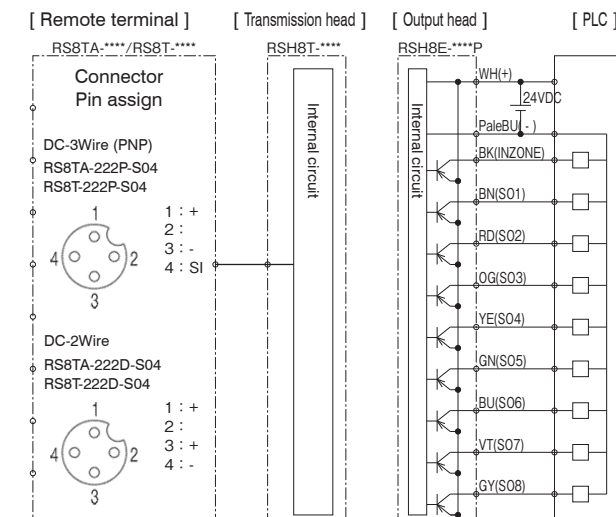

Remote Terminal

Remote Terminal : RS8TA-222D-S04 / RS8TA-222P-S04 / RS8T-222D-S04 / RS8T-222P-S04

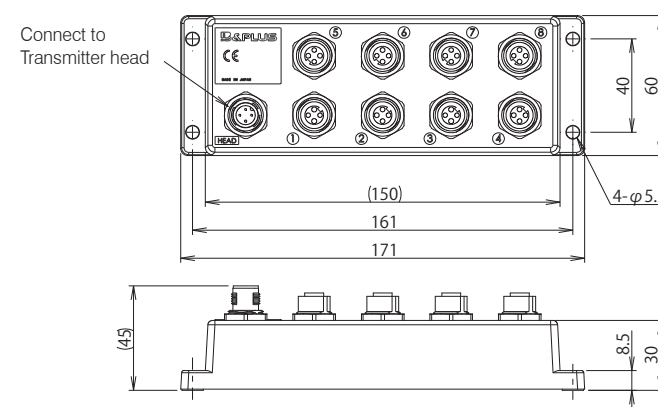

Applicable angle connector type (Detector's connector)

When using an angle connector, please use a connector of which key is positioned same as the following figure.

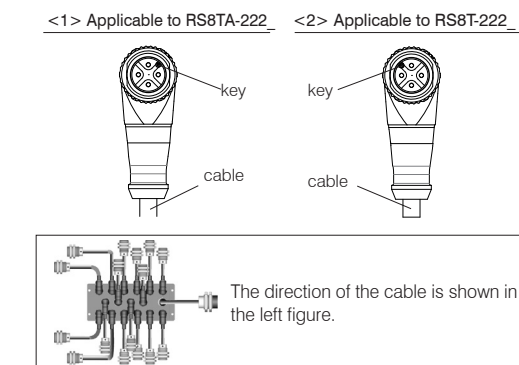

	DC 2-wire detector switch	DC 3-wire detector switch
Type code	typ-1 RS8TA-222D-S04	RS8TA-222P-S04
(see connector type)	typ-2 RS8T-222D-S04	RS8T-222P-S04
Applicable Transmission head	RSH8T-030-PU-CP-_, RSH8T-TF030-PU-CP-_	RSH8T-030-PU-CP-_, RSH8T-TF030-PU-CP-_
Applicable Detector SW	DC 2-wire	DC 3-wire
Driving Voltage	22 V DC ± 10%	12 V DC ± 10%
Driving Current	5 mA (1 signal)	150 mA
Connection Detector SW	max. 8 signals	max.8 signals
Spec of	Supply Voltage	22 V DC ± 10 %
ON Voltage	= < 6.5 V	= < 3.5 V
Detector SW	Load current	= > 5 mA
Leakage current	= < 1 mA	= < 0.1 mA
Material Housing	PPS	PPS
Ambient temperature	0...+50 °C	0...+50 °C
Protection class	IP67	IP67

The unused connector should be protected in an exclusive protection cap (option).

protection cap	PROT-M12
----------------	----------