

User's Guide	
Switch signal / [4+4]signal transmission type	
Remote	: RHPT8-8010N-C3-PU : RHPT8-8010P-C3-PU
Base	: RHPE8-8010N-C3-PU : RHPE8-8010P-C3-PU

## Safety Considerations

Please read carefully before using and full attention to Safety Considerations.

### Construction of the system

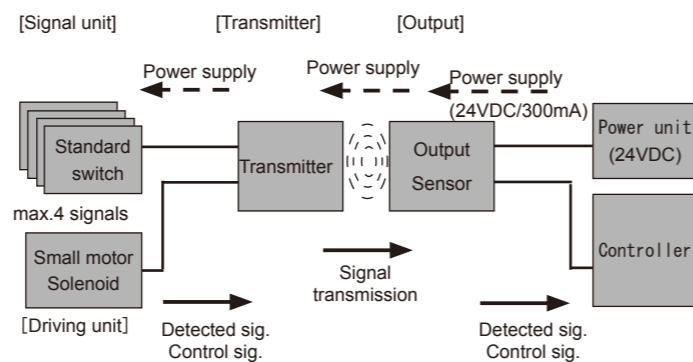

#### [Function of each component]

Driving unit : Small motors, solenoid valves can be connected.

Signal unit : Connects signal units such as detector switches or controllers.

Remote : A unit which is installed on the moving side and has following functions: to supply power for connected actuators, to transmit input signal from "detectors" to "base" and to output the transmitted signals from "base" to "detectors".

Base: A unit which is installed on the fixed side, and it has following functions: to supply power for "remote" to "external controller" to "remote".

### Dimension and Specification

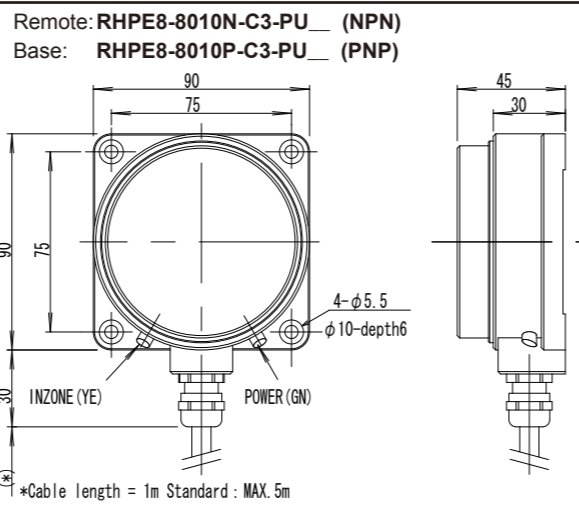
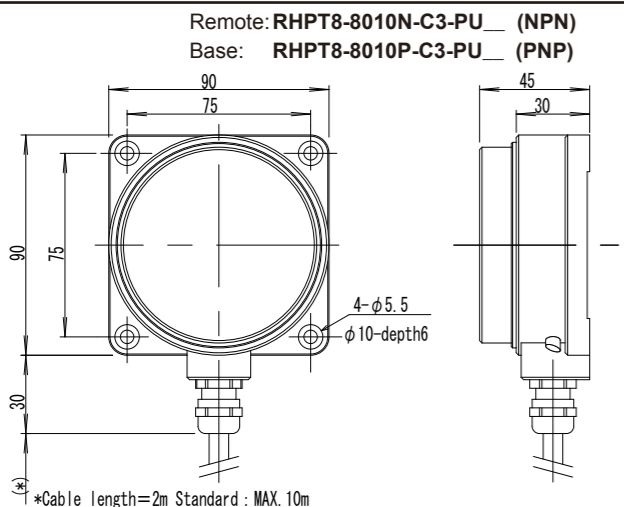

Type code	RHPT8-8010N-C3-PU-01	RHPT8-8010P-C3-PU-01
Driving voltage	24V ± 1.5V DC	
Driving current	≤ 300mA	
Transmission area <sup>2)</sup>	Distance : 3...10mm / Center offset : ±7mm	
Input <sup>1)</sup>	Signals	4 signals (SI1...4)
	Input type	NPN / PNP
	Current load	7mA/1 input
Output <sup>2)</sup>	Signals	4 signals (SO1...4) +1 signal (Inzone)
	Output type	NPN / PNP
	Current load	≤ 50mA/1 output
Operating temperature	0...+50 deg.C.	
Protection class	IP67	
Cable	PUR / φ 7.7 , 2x0.5mm <sup>2</sup> + 9x0.18mm <sup>2</sup>	
Material	Body	Aluminum + Alumite treatment
	Active face	ABS+PBT
Weight	600g + 100 g × 1m (cable)	

1) Input from the sensor to RHPT8, 2) Output to the actuator from RHPT8

Type code	RHPE8-8010N-C3-PU-02	RHPE8-8010P-C3-PU-02
Supply power	24V DC ± 10% (incl.ripple)	
Current consumption	≤ 1.5A	
Input <sup>3)</sup>	Signals	4 signals (SI1...4)
	Input type	NPN / PNP
	Current load	7mA/1 input
Output <sup>4)</sup>	Signals	4 signals (SO1...4) +1 signal (Inzone)
	Output type	NPN / PNP
	Current load	≤ 50mA/1 output
Frequency	40Hz	
LED indication	Inzone / Power	
Protection class	IP67	
Cable	PUR / φ 7.7 , 2x0.5mm <sup>2</sup> + 9x0.18mm <sup>2</sup>	
Material	Body	Aluminum + Alumite treatment
	Active face	ABS+PBT
Weight	600g + 100 g × 2m (cable)	

3) Input to the RHPE8 from the host device, 4) Output to the host device from RHPE8

### Wiring diagram

#### NPN type

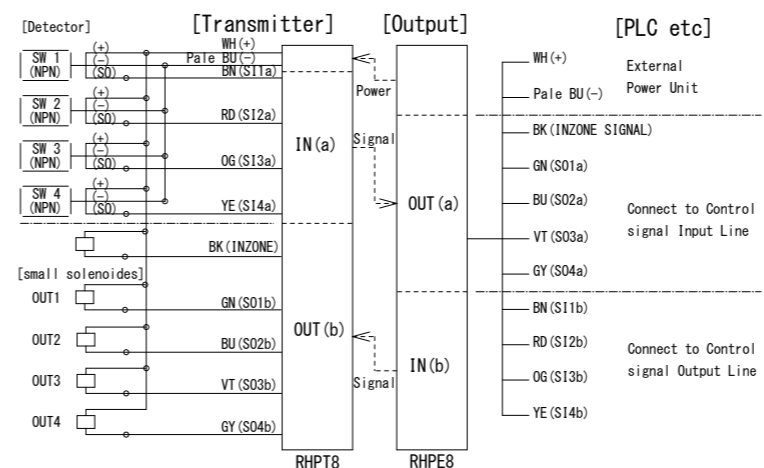

#### PNP type

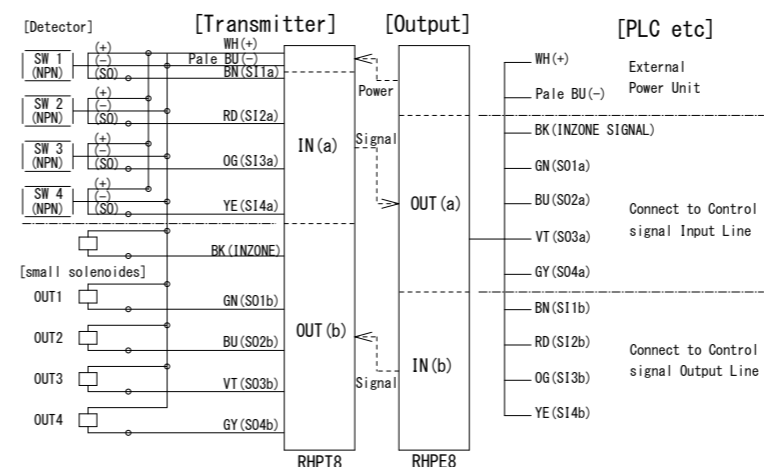

#### (Note)

Please note that the cable length of an output sensor may not longer than 10m. The CE marking verifies that our products comply with the requirements of EMC directive. The surge test to an output sensor is not carried out. When using an output sensor with cable length longer than 10m, a measure to protect the sensor from surge current should be taken.

### Transmitting area diagram [Example: Supply voltage at 24V DC]

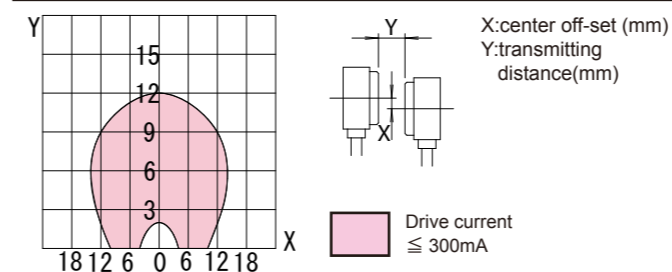

### Influence of surrounding metal

To avoid influence of surrounding metal, keep minimum spacing as described below;

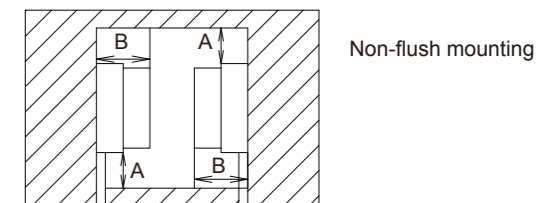

Type number	A (mm)	B (mm)
RHPT8-8010N/P-C3-PU	50	45
RHPE8-8010N/P-C3-PU		

### Mutual interference

In order to prevent mutual interference between parallel-mounted sensors, keep minimum spacing as described below;

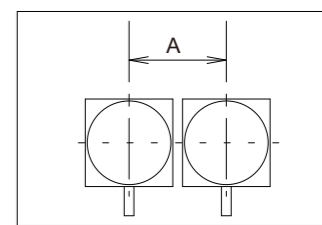

Type number	A (mm)
RHPT8-8010N/P-C3-PU	300
RHPE8-8010N/P-C3-PU	

### Bending radius of cable

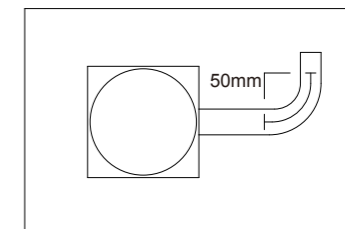

# Safety Considerations

Please read carefully before using and full attention to Safety Considerations. Incorrect handling may cause not only malfunction or failure, leading to an accident or injury. Also in order to prevent damage or injury, please look after.

## ■ Precaution regarding architectonic

- Remote sensor series are a system, which supplies/transmits power/signals wirelessly. Please do not use the system except for this purposes. The processor must be operated only using approved power supplies. There can be a risk of fire or heat generation exceeds the rated voltage when power is being supplied"
  - The processor must be operated only using approved power supplies. Incorrectly connected wiring may cause malfunction or unexpected problems.
- Please install an apparatus in the standard setting of the products. Transmission distance, Axis gap, drive voltage, drive electric current set of this product, and, please install an apparatus according to ambient temperature,surrounding metal (the side, facing side) mutual interference. It can cause degradation to the internal part and cause malfunction.
- Even if the abnormality of power supply and this product break down, please design the system so that the whole system acts on the safe side.

## ■ Specification and regulations compatibility

- The control communication device that is installed in the product, there is no need for (diploma) radio station authorization of the Minister so apply to "a weak radio station (weak radio equipment)" to. However, please be careful on the occasion of the operation because it may affect medical equipment and electronic equipment (such as pacemakers).
- To a product EMC Directive order, CE marking is on the product appearance or a cable. When using an output sensor with cable length longer than 10m, a measure to protect the sensor from serge current should be taken.
- The product of the output more than 50W needs permission application to use high frequency in the facilities. You will have to apply in accordance with high frequency utilization equipment authorization procedure by the Ministry of Internal Affairs and Communications. For more information, please refer to the website of the Telecommunications Ministry of Internal Affairs and Communications.
- Some products, because it is Japan specification, it can not be used outside of Japan.
- The rules for such standards and systems of customers who use the product to be fit, after confirmation, please take appropriate action on your own.

## ■ Power and the wiring

- If you want to support the installation, maintenance, and failure, please work after confirming that the main circuit breaker (power board) is always out when working with hot-state, there is a potential for electric shock.
- Please ensure proper procedure to street work. Improper installation work can cause malfunction or an electrical shock, or the cause of the fire.
- Use a regulated power supply, e.g. Switch-model type. (Simpler power supplies, such as a full-wave rectification type,will cause the permissible ripple rating to be exceed and may cause malfunction.)
- When wiring the power supply or signal lines, please follow the chapters containing the , manual, and wire all connection properly. Incorrectly connected wiring may cause malfunction, unexpected problems."
- To avoid malfunction caused by induction noise, cable should be kept apart from motor or other cables.

## ■ Surrounding metal

Please avoid facing the base part with metal continuously. By heating the metal, damage of inside element can be caused.

When power is turned on while cutting chips or pieces of metal exist on the transmission surface, the head and the metal piece heats up and this may cause for unexpected accidents or damage to the equipment. Please be sure to run the system after removing metal chips and slugs from transmission surface.

- Do not put your hands or metal objects between the coils during operation There and heat generated by induction heating, the potential to catch fire.

Make sure to keep minimum spacing, when installing, in order to avoid influence with the surrounding metal, have space indicates on the manual. (Please see "Surrounding metal" on the back page.)

## ■ Transmission range

- When the unit keeps to be using under out-of specification transmission distance/center offset/overload status for long time, it may be damaged by overheating.
  - The in zone signal becomes the spare signal for the confirmation that an output signal establishes in the use in the specifications range. Please be careful that it is not guarantee the signals without of specifications.
  - Please note that when transmission distance and an axis gaps are out of range specifications, it can become unstable in a signal (a false signal and chattering)
  - Please note that when using remote coupler system, out of range specifications can cause unstable in a signal (a false signal and chattering)
- Facilities operation can be influenced by chattering.
- When influenced by chattering, remote part / base part is in the range, add a relay between power supply wiring from outside control equipment to base region in the domain specifications range, and turn on or off the power.

## ■ Installation

- A detection sensor to connect and the drive unit, please use a thing working definitely in a voltage reading range prescribed to the drive voltage.
  - The total current consumption of connecting sensor and driving units must not exceed the value of Drive current. The drive current is affected by transmission distance and center offset. (↑ Transmitting area diagram.)
  - When using a mechanical switch,please use the micro-load type without LED.
  - Please make sure to consider the self-fever of this product and have the ambient temperature be below the service temperature.
  - It is recommended to install on metal in order to reduce the influence of self-heating.
  - When installed in a place such as hot air heater or direct sunlight directly, it could cause a malfunction or fire.
  - Please follow the apparatus specifications, and have the head opposed correctly.
  - In order to avoid influence of surrounding metal, or to avoid mutual influence between parallel-mounted sensors, keep the minimum free zone as described below.
- There is a possibility to break down if sending and electric current having the base parts facing each other or apply power supply to the remote part. (Please see "Parallel installation" on the back page.)
- With the case and transmission that uses resin material (ABS or ABS+PBT) please make sure the liquid including organic solvent is not surrounded by these liquid)
  - This product is designed for indoor use. Please use it indoors. The malfunction or accident, the cause of the fire. Such as metal objects or combustible enters, and will be set to smoke or fire due to short circuit or malfunction, fire, electrical shock or other damage.
  - Consider the inrush current. It may generate when starting a system. And please have them set up accordingly. For certain items we also have products to prevent inrush current.

## ■ About cable

- Make sure to install so that the end (wiring part) of the cable will not get water on it.. (Water can handed down to the main body from the cable core line and may lead to malfunction such as a short circuit or the corrosion.)
- When wiring the cable bending radius, please install so that the cable exits are straight (approx 10mm). Please secure bend radius determined by an instruction manual or User's Guide. Never pull the cable strongly.

## ■ Others

- There will be a rise time to supply appointed electricity. After confirming in zone signal and then base part and a remote part faces each other. Please check the specification manual or the user's guide about the boot-time. If there is no boot-time mentioned, boot-time for remote sensor system is  $\leq 0.2$ sec.
- Please don't resolution remodeling or modify the product. Failure to do so may result in fire, electric shock or malfunction. In addition, there is a risk that can lead to serious injury. When I perform the resolution and remodeling, a guarantee may not be received.
- Smoke, or in the case of such an abnormal state when abnormal noise or offensive smell is, please stop using it immediately. The malfunction or electric shock , the cause of the fire.
- If you want to dispose of this product, you will be disposed of as industrial waste.
- Always, use the specified parts and accessories. , It can cause the malfunction or accident or the cause of the fire.
- With the product mounted with a cooling fan, please prevent from blocking the fan. Heat build up inside and cause malfunction or fire.
- While working or immediately after operation, please do not touch the ( power supply unit, charging Unit, Head part) hot spots. It can cause the burn.
- Specifications subject to change without notice. If there is a point of notice about the contents of this document, feel free to contact us, thank you.

## [Precaution for product of the charge type]

- The product of the charge type becomes the product for 12VDC battery, 24VDC battery and appointed lithium-ion batteries. It cannot be used other than charging battery and battery appointed with each product. The malfunction or cause of the fire.
- Because the voltage that is higher than battery is applied at the time of the charge, please make sure to check the voltage range of an apparatus connected to battery or appropriate voltage license, please prepare converters.
- The charge time of the battery varies according to a consumption electric current and the charge time of the use apparatus. Please choose the most suitable product . Please contact for simple simulation requests.
- Because the prescribed charge voltage and charge condition vary according to each battery, the lithium in battery cannot take responsibility to any other than our recommendation battery