

■ Dimension

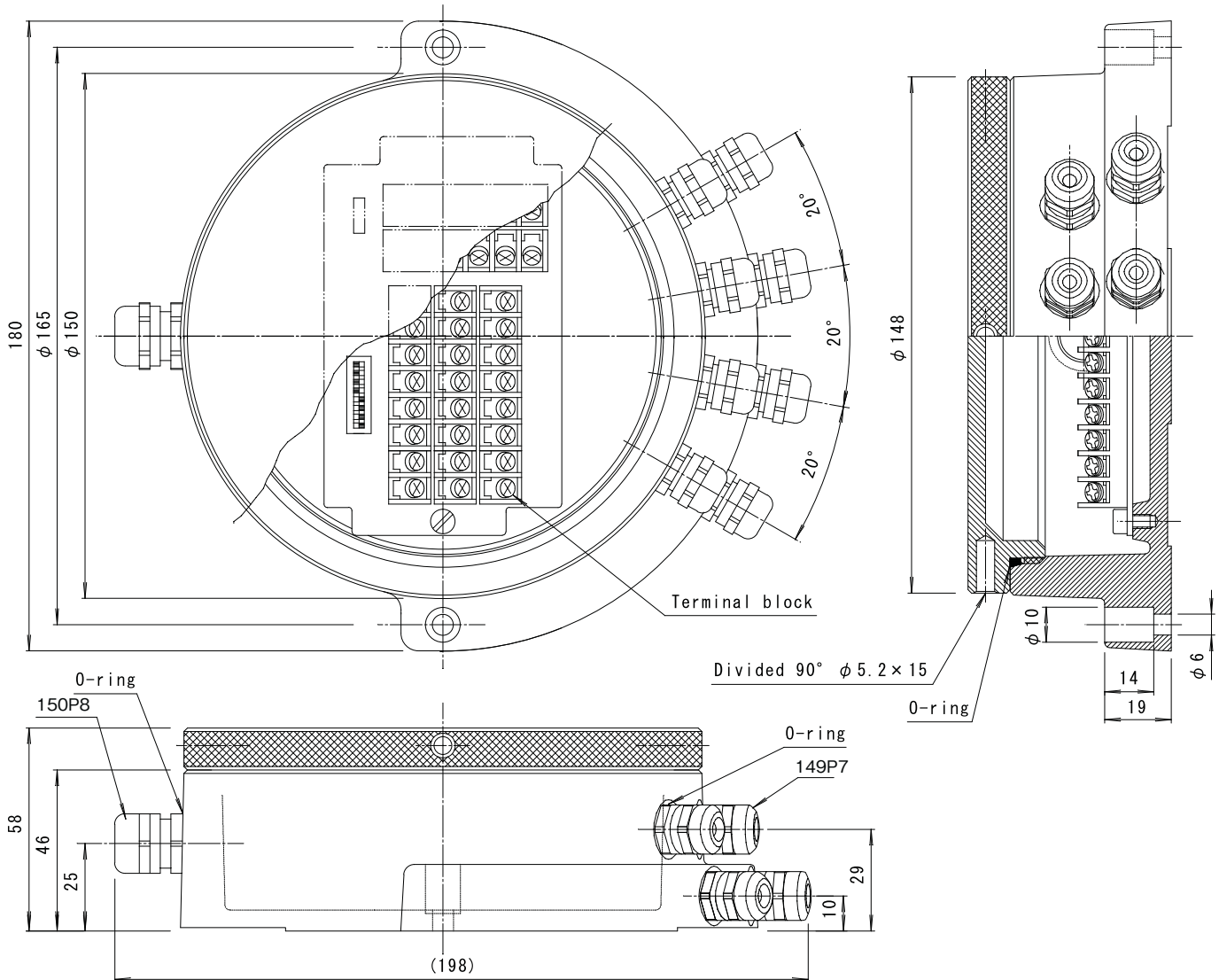

Attention for Safty



[Planning the system]

The Terminal Box for the Remote Sensor is an enclosure which connects the Detectors with the Transmitter of the Remote Sensor and transmits the detected signals. The Terminal Box should only be used for this purpose. Plan the system to work safely if the Terminal Box should be damaged.

[Handling the Terminal Box]

Make the correct wiring and connect as referred to the wiring diagram of this manual. Wiring errors may cause system failure. Make sure that the power is turned off, when start the installation process. Never take the device apart or modify. Dispose of the device as an industrial waste.

■ Specification

Protection Class	IP67	
Material	Housing	Aluminum sand mold casting
	Lid	Aluminum cutting
	O-ring	Viton
Terminal block	Transmitter	6 poles x 2 / Terminal Screw : M3
	Detector	8 poles x 3 / Terminal Screw : M3
Procedure for Mounting	Attaching by two M5 screws	
Cable Gland	Mounted on the Terminal Box	
	Transmitter	150P8 (O-ring attached) : 1pc.
	Detector	149P7 (O-ring attached) : 8pcs.
	Accessories	Blank Plug BP0525 : 8pcs. (Supplied together with the Terminal Box)

■ Transmitter of DC 3-Wire at use.

● Detector of NPN

Transmitter : RPTA-8010-PU
 RGPT-3005-V1215-PU
 RGPT-4008-V1220A/B-PU
 RGPT-9012-V2430-PU

Detector : DC 3-Wire Detector switch (NPN)
 DC 2-Wire Detector switch
 RFD series
 Mechanical switch

● Terminal block No.

CN1,CN2 : Connecting Transmitter
 CN3 : +
 CN4 : SI1...8
 CN5 : -

● Setting DIP switch

Detector switch	NPN/PNP Selector	DC 2-Wire/3-Wire Selector
DC 3-Wire SW	NPN	OFF
DC 2-Wire SW		ON

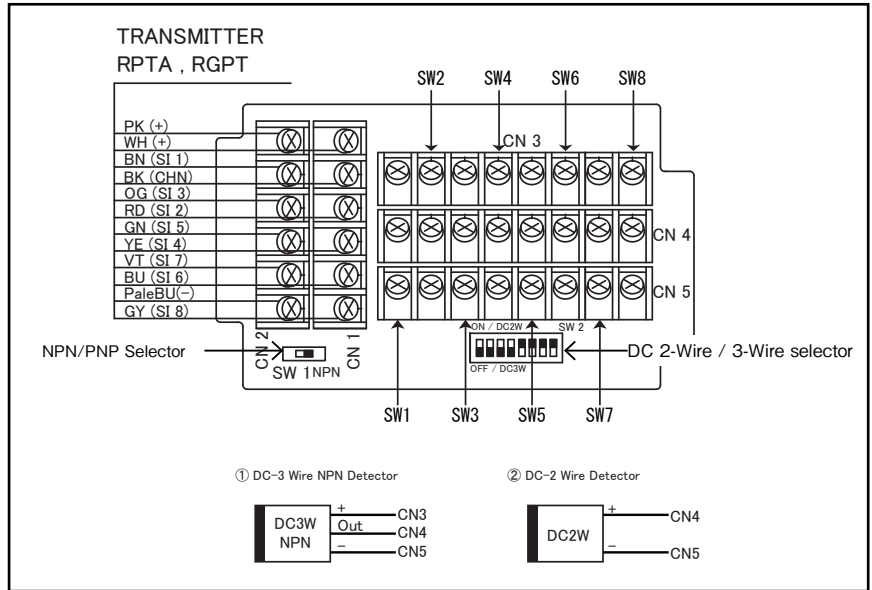

● Detector of PNP

Transmitter : RPTA-8010-PU
 RGPT-3005-V1215-PU
 RGPT-4008-V1220A/B-PU
 RGPT-9012-V2430-PU

Detector : DC 3-Wire Detector switch (PNP)
 DC 2-Wire Detector switch
 RFD series
 Mechanical switch

● Terminal block No.

CN1,CN2 : Connecting Transmitter
 CN3 : +
 CN4 : SI1...8
 CN5 : -

● Setting DIP switch

Detector switch	NPN/PNP Selector	DC 2-Wire/3-Wire Selector
DC 3-Wire SW	PNP	OFF
DC 2-Wire SW		ON

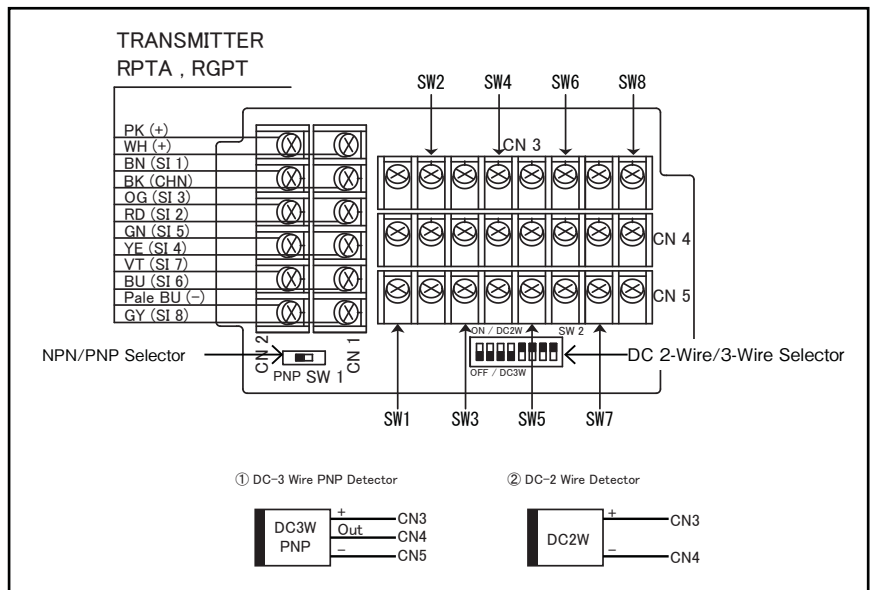

■ Transmitter of DC 2-Wire at use.

● RPT8-1803D-PU、RS08TA-018D-PU

Detector : DC 2-Wire Detector switch
RFD series
Mechanical switch

● Terminal block No.

CN1,CN2 : Connecting Transmitter } Connecting
CN3 : + } Detector
CN4 : SI1...8 }

● Setting DIP switch

Detector switch	NPN/PNP Selector	DC 2-Wire/3-Wire Selector
DC 2-Wire SW	PNP	OFF

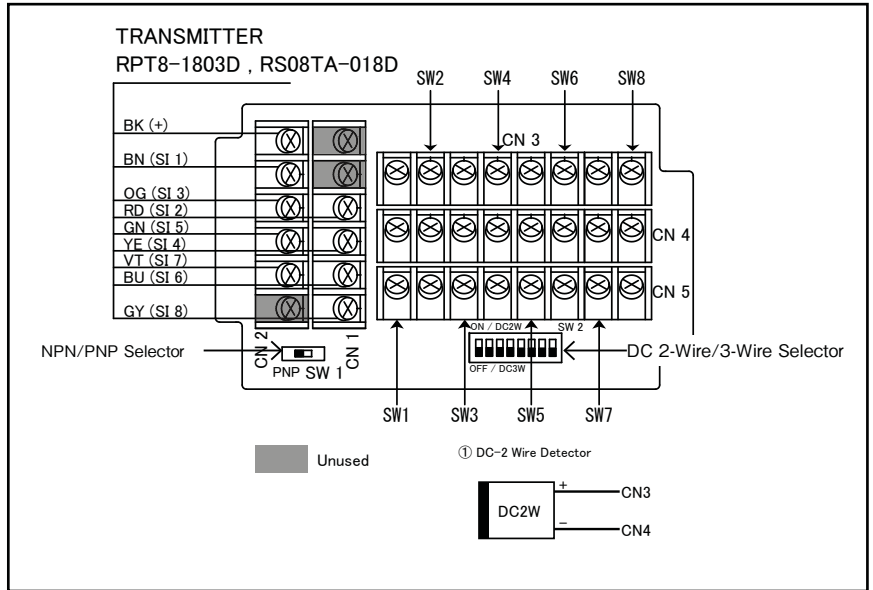

● RPT8-3007D-PU

Detector : DC 2-Wire Detector switch
RFD series
Mechanical switch

● Terminal block No.

CN1,CN2 : Connecting Transmitter } Connecting
CN4 : SI1...8 } Detector
CN5 : - }

● Setting DIP switch

Detector switch	NPN/PNP Selector	DC 2-Wire/3-Wire Selector
DC 2-Wire SW	NPN	OFF

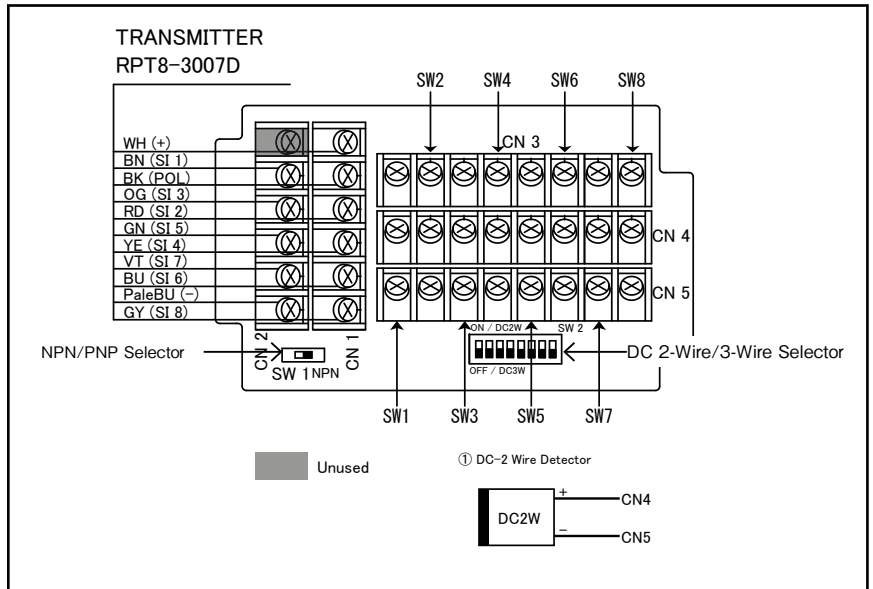

● RPT8-3007D-TYT19

Detector : DC 2-Wire Detector switch
RFD series
Mechanical switch

● Terminal block No.

CN1,CN2 : Connecting Transmitter } Connecting
CN3 : + } Detector
CN4 : SI1...8 }

● Setting DIP switch

Detector switch	NPN/PNP Selector	DC 2-Wire/3-Wire Selector
DC 2-Wire SW	PNP	OFF

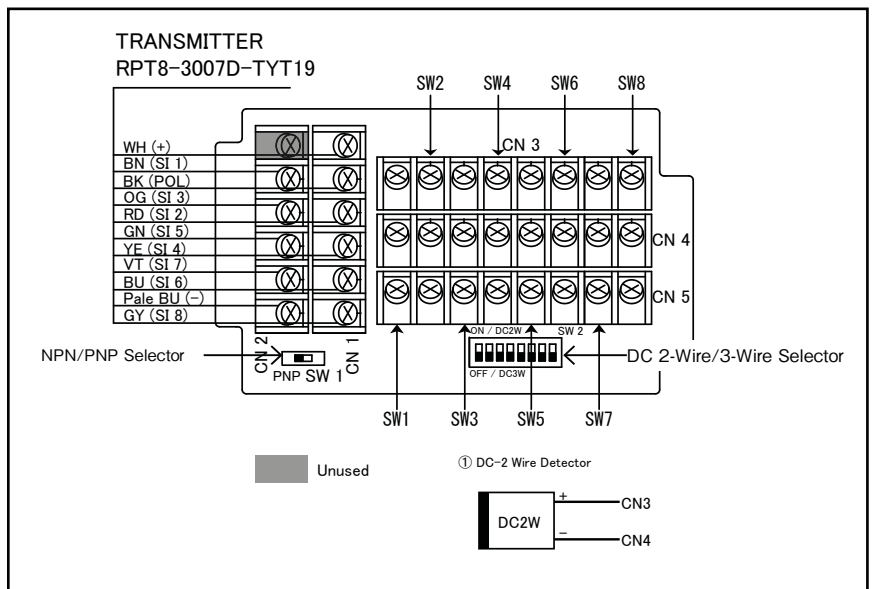

[Installation for Terminal Box]

- ① Attach the Terminal Box fasten with 2 Allen screws.
Size ; M5 Length ; longer than 20mm
- ② It is recommended to apply adhesive for tightening screws to avoid loosening of screws.

[Connection of the Transmitter and the Detector]

● **Processing of Cable (example) / Fastening Position of Cable <Fig. 1>**

- ① Process the cores of cable to adapt to the terminal.
- ② Make sure that outer sheath of cable is positioned inside of the Terminal Box properly in tightening cable.<Fig. 1-a>

● **Processing of Cable (example) / Fastening Position**

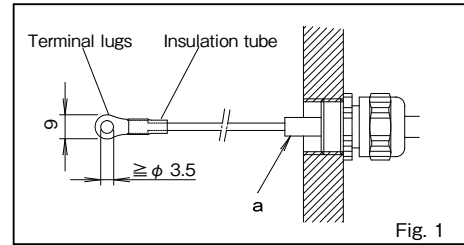

● **Mounting of Cable <fig. 2>**

Put a cap and sealing ring on cable, then insert the cable to the body.

● **Mounting Cable**

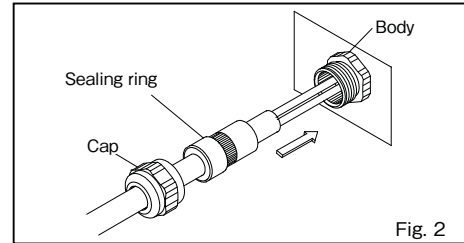

● **Tightening of the Cable Gland <fig. 3, 4>**

Put a cap on the Cable Gland and tighten it with a spanner.

Spanner caliber Transmitter : 17mm <Fig. 3>
Detectors : 14mm <Fig. 4>

<Caution> When the cable clamp is not fit into slot on the Cable Gland, or tightening of the Cable Gland is done improperly, it may have influence on its water tight quality.

● **Tightening Cable Gland**

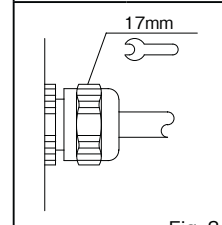
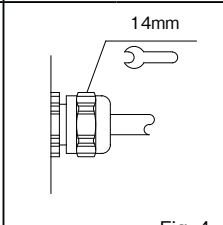
Cable Gland for Transmitter		Cable Gland for Detectors	
	17mm		14mm
Fig. 3		Fig. 4	
Cable diameter	Tightening torque	Cable diameter	Tightening torque
φ 5.0...8.0	6Nm	φ 4.0...6.5	6Nm
The cap can be shut up tightly to the body.			

● **Measure of unused Cable Gland <Fig. 5>**

Insert the blank plugs (φ 5mm) supplied with the Terminal Box into any unused cable entrances of the Cable Gland and stop it.

- ① Insert the blank plug.
- ② Tighten the Cable Gland.(Refer to Tightening of the Cable Gland for Detectors . Fig. 4)

● **Connecting to terminal block**

In accordance with the wiring diagram on page 3,4 , connect cores to each appropriate terminal.

<Caution> Insert the cores to reach the terminals sufficiently.
In the case of a core was inserted insufficiently, the following problems are may caused ;
[A core is not reach to a terminal] The core come out or cause short circuit with adjoining cables.
[A core is inserted exceedingly] The core cannot be connected sufficiently because of terminal catching insulations.
Coolant or cutting chips should not be splashed on inside of the Terminal Box in wiring operation.

● **Measure of Unused Cable Gland**

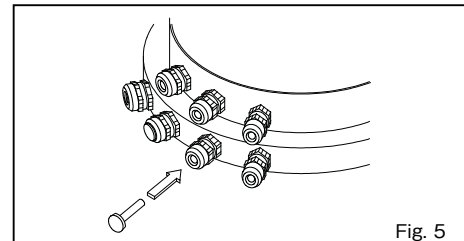

[Tightening of the lid on the Terminal Box] <Fig. 6>

- ① Make sure that the O-ring is equipped with the lid properly.
(Check the O-ring whether it has any flaw)
- ② Check the wiring condition to avoid the lid catching of the lead wire, and clean the Transmitting Amplifier with air blow and dry it with heat gun in tightening of the lid.
- ③ Fit the lid on the Terminal Box to wrench close the lid smoothly or not to damaged thread of the lid, and insert it properly.
- ④ Tighten the lid reach the Terminal Box with your hand, then insert appropriate tools into holes (φ 5.2) on the side of the lid and fasten it tightly. (turn the lid 30...40°)

● **Fastening Lid on the Terminal Box**

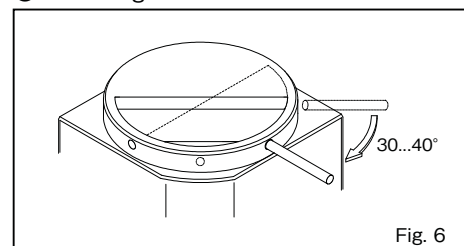

[Bending Cables] <Fig. 7>

Using sensors with its cable bending, bend cables at a point that apart more than 10mm from the cable entries of the Cable Glands.
Refer to specification of each sensors regarding bending radius for cables.

● **Bending Cables**

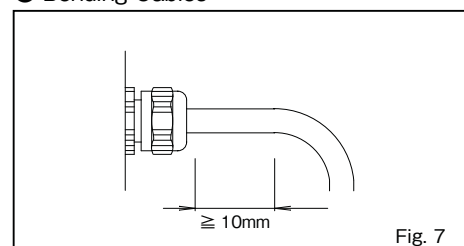

[Attention for Watertight Quality]

The value that indicated in this guide is the recommended value to fulfill the protection class IP 67.

Protection with a cover is required if the Terminal Box will be exposed to coolant since elasticity of cables vary with the material.

[Replacement of Cable Glands]

Replace the sealing rings of Cable Glands when you change sensors in maintenance to avoid decline of its watertight quality.

Sealing ring	Code	Type number
for transmitter	991995008	KBC-F2/E150P8
for detector	991995007	KBC-F2/E149P7

B & PLUS K.K. (Former NIHON BALLUFF co.,Ltd)

URL <http://www.b-plus-kk.jp>

Specifcations are subject to change without no tice.