

[Dimension]

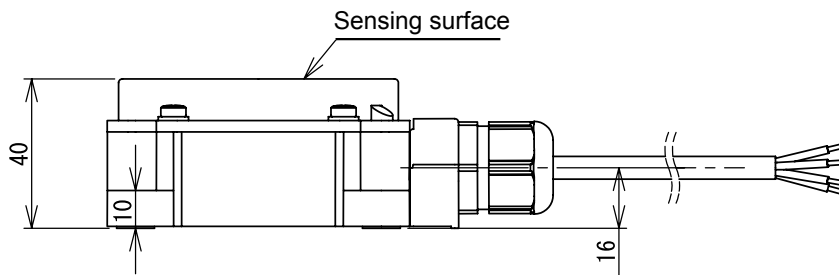
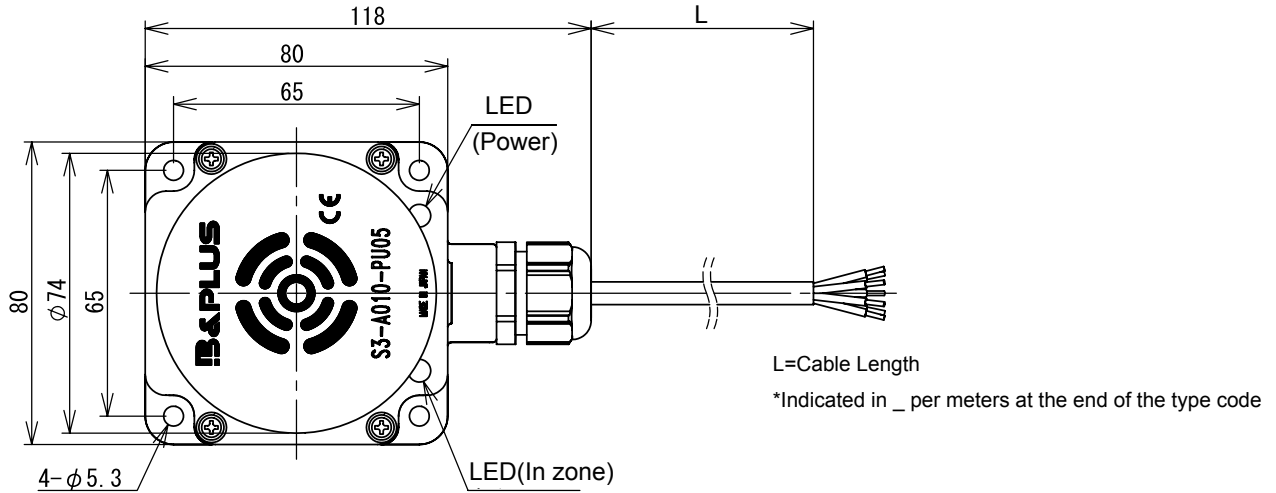

Cable wiring color

Color	Signal
Black	SOUT1
Black / White	SOUT2
Green	SIN1
Green / White	SIN2
Red	20V+
Red / White	20V-
Shield	FG

[Specification]

Operating temperature	0...+50 deg.C.
Operating humidity	35...90% RH
Storage temperature	-20...+80 deg.C
Storage humidity	35...90% RH
Isolation	≥ 50M Ohm (at DC500VM), case to circuit
Dielectric strength	1000 VAC / 1 min. case to circuit
Vibration rating	10...55 Hz, amplitude 1.5 mm 2 hrs. each axis to x-y-z.
Protection class	IP67
Cable	PUR, Phi 6 mm 3P x 0.25
Housing material	PBT+ABS
Weight	400g + Cable70g / m
Applicable ID tag	S1-D011-8K, S1-D021-8K

Type code	S3-A010-PU_ _	Date	2013.01.31	Rev.	A	Value date	2013.01.31	Contents.	New document.
		No.	D713111Ae						
		3RD ANGLE P.		1/2					